

REV.	DATE	DESCRIPTION	APPR.
A	3/25/08	REMOVED NONEXISTENT PART #s	ERL

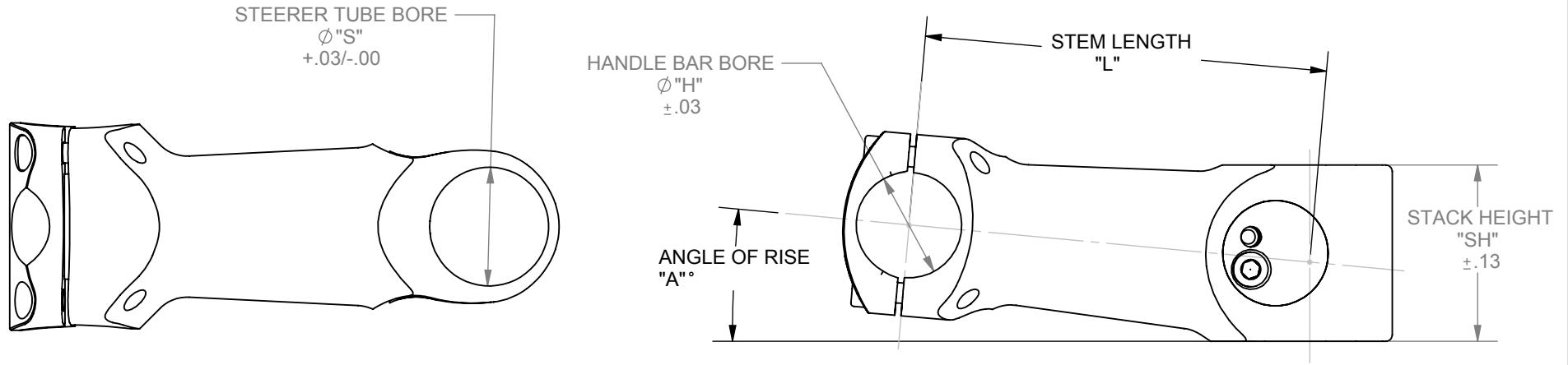

Model Number	Description	"S"	"L"	"A"	"H"	"SH"
SM-E101	5 deg x 100 x 25.4	28.68 mm	100 mm	5	25.45 mm	42.545 mm
SM-E102	5 deg x 110 x 25.4	28.68 mm	110 mm	5	25.45 mm	42.545 mm
SM-E103	5 deg x 120 x 25.4	28.68 mm	120 mm	5	25.45 mm	42.545 mm
SM-E104	5 deg x 130 x 25.4	28.68 mm	130 mm	5	25.45 mm	42.545 mm
SM-E106	15 deg x 100 x 25.4	28.68 mm	100 mm	15	25.45 mm	42.545 mm
SM-E107	15 deg x 110 x 25.4	28.68 mm	110 mm	15	25.45 mm	42.545 mm
SM-E108	15 deg x 120 x 25.4	28.68 mm	120 mm	15	25.45 mm	42.545 mm
SM-E109	15 deg x 130 x 25.4	28.68 mm	130 mm	15	25.45 mm	42.545 mm
SM-E111	5 deg x 90 x 25.4	28.68 mm	90 mm	5	25.45 mm	42.545 mm
SM-E112	15 deg x 90 x 25.4	28.68 mm	90 mm	15	25.45 mm	42.545 mm
SM-E113	-10 deg x 90 x 26.0	28.68 mm	90 mm	-10	26.01 mm	42.545 mm
SM-E114	-10 deg x 100 x 26.0	28.68 mm	100 mm	-10	26.01 mm	42.545 mm
SM-E115	-10 deg x 110 x 26.0	28.68 mm	110 mm	-10	26.01 mm	42.545 mm
SM-E116	-10 deg x 120 x 26.0	28.68 mm	120 mm	-10	26.01 mm	42.545 mm
SM-E117	-10 deg x 130 x 26.0	28.68 mm	130 mm	-10	26.01 mm	42.545 mm
SM-E125	0 deg x 50 x 25.4	28.68 mm	50 mm	0	25.45 mm	42.545 mm
SM-E126	0 deg x 70 x 25.4	28.68 mm	70 mm	0	25.45 mm	42.545 mm
SM-E156	0 deg x 50 x 22.2	28.68 mm	50 mm	0	22.23 mm	42.545 mm

THIS DOCUMENT/DATA RECORD IS THE PROPERTY OF L.H. THOMSON CO. AND CONTAINS PROPRIETARY AND CONFIDENTIAL INFORMATION, AND IS NOT TO BE COPIED.

UNLESS OTHERWISE SPECIFIED DIMENSIONS ARE IN mm TOLERANCES:  
 ANGLES  $\pm 1^\circ$  DECIMALS  $\pm .25$   
 FINISH 3.2 RA MAX  
 BREAK CORNERS .30-.60 RAD

USED ON: L.H. Thomson Web Site	DRAWN: R. De Rose CHECKED: D. Parrett	DATE: 12-13-04 DATE: 12-13-04	<b>L.H. THOMSON COMPANY</b> <small>CORPORATE OFFICES</small> <small>MACON, GA 31297</small>
SECTION NO.	STRESS: ENGR:	DATE: DATE:	
CHANGE NO.	M.E.:	DATE:	<b>ELITE STEM SIZE DIAGRAM</b>
GROUP ORIGIN:	GROUP: PROJ. PIN: <PART ID NO>	DATE: DATE:	
SIZE CAGE CODE DRAWING NO. <b>A</b> WEB 005			FILE: I:\cad\prt\115100\005 Elite Stem REV_A SHEET 1 OF 1